

스텝핑 모터 (Model : SE-SM9) 스펙

뉴테크놀로지 컴패니(N.T.C)

<http://www.NewTC.co.kr>

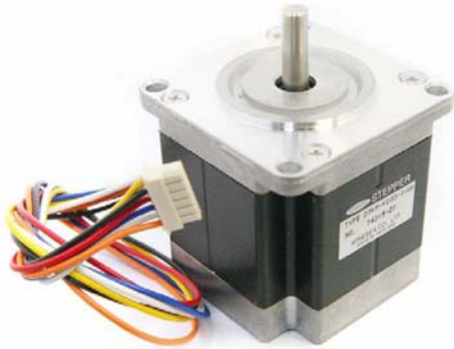

■ Application

소형 이동 로봇
 컨트롤 장비

■ Specification

Step Angle ($^{\circ}$)	Voltage (V)	Current (A)	Resistance (Ω)	Inductance (mH)	Holding Torque (Kg \cdot cm)	Rotor Inertia (g \cdot cm 2)	Weight (g)
1.8	24	3	0.9 \pm 10%	1.8 \pm 20%	9	320	680

Note

1. The drive system be based on 2 phase-excitation by constant current driving.
2. Please do not drop or shock against hard material.
3. Please do not disassemble motor.
4. Please do not machine the motor shaft without a proper tool for the assurance of motor performance

■ Circuit Diagram

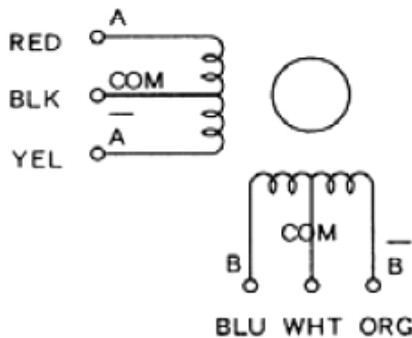

▶ Pin connection

1	2	3	4	5	6
Red (A)	Black (Com)	Yellow (/A)	Blue (B)	White (Com)	Orange (/B)

■ Dimension

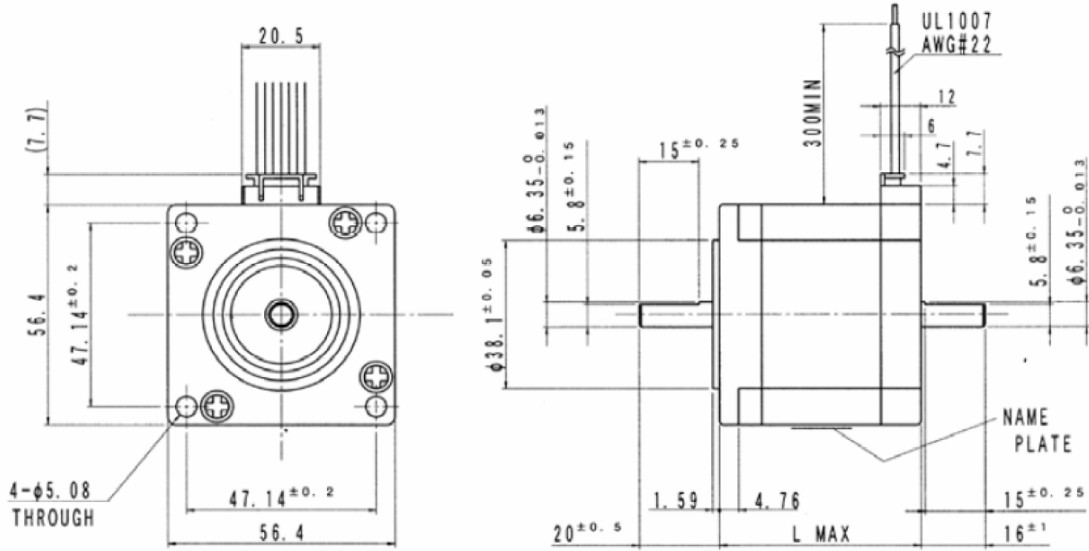

■ 사용 방법



스텝핑 모터 구동모듈 AM-CS2(P)

입력 신호 : A, /A, B, /B 각 상의 신호

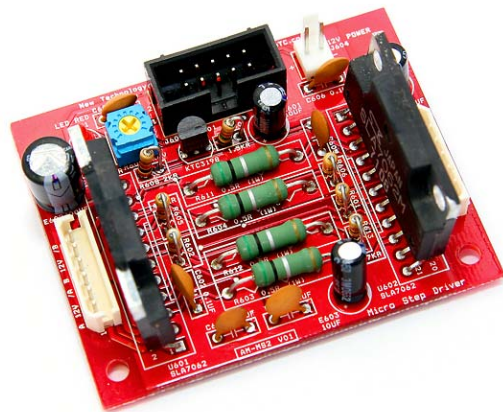
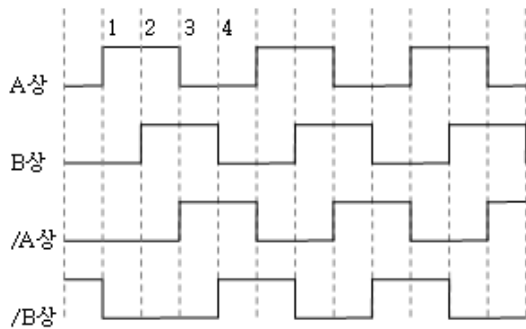

스텝핑 모터 클럭 구동모듈 AM-MS2

입력 신호 : Dir(방향), CLK(속도) 신호

